

T&B® Fittings

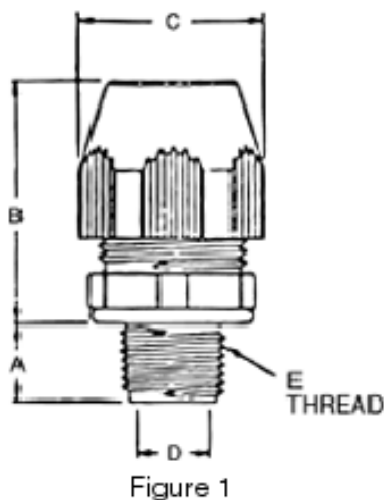

T&B Catalog Number: LT50P
UPC Number: 78621045065
Description: 1/2" Non-Metallic liquidtight Bullet® - Straight. For use with liquidtight non-metallic Type B conduit or liquidtight non-metallic tubing.
Status: Active



Features

- Outside surface has friction reducing ridges.
- Inner surface teeth bite into conduit or tubing to enhance clamping and sealing action.
- Fitting ferrule designed to accept variations in conduit sizes and field conduit cuts.
- Smooth ferrule profile reduces friction to ensure a tight conduit-to-fitting seal.

Application

The Bullet® meets performance requirements when terminating Type B liquidtight non-metallic conduit or flexible non-metallic tubing to a box or enclosure with knockout opening or threaded hub.

General

Trade Size (inches)	1/2
Material	Thermoplastic

Dimension Information

Dimension A (inches)	0.570
Dimension B (inches)	1.636
Dimension C (inches)	1.448
Dimension D-Minimum Throat (inches)	0.550
E- NPT Thread (inches)	1/2-14
A (mm)	14.48
B (mm)	41.55
C (mm)	36.78
D (mm)	13.97

Packaging

T&B Inner Pack	20
Package in Units	100
T&B Sold in UOM	Each
T&B Weight Per UOM	8.9 lbs. per 100

Application Support

T&B Instruction Sheets	ta00998-tb2
Guide to Nonmetallic Conduit Applications	Available on Website
XTRAFLEX System Specifications	Available on Website

Notes

*Note: Suitable for hazardous locations; Class I Div 2; Class II Div 1 & 2; Groups E, F, G; Class III per N.E.C.; Article 501-4, 502-4 and 503-3

Certifications

RoHS Compliance	Yes
-----------------	-----

Certifications



File Nbr:
E 23018

XTRA FLEX® System —

Conduit, Tubing, Fittings for Non-Metallic Liquidtight Conduit



The BULLET® non-metallic liquidtight fitting — easy to use, built to take it!

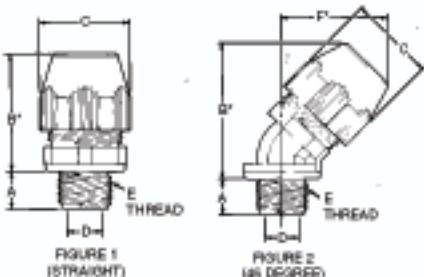
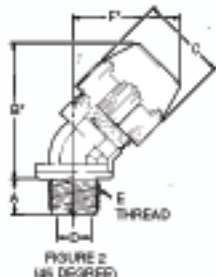
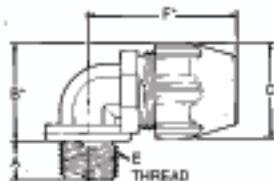

- Outside surface has friction-reducing ridges
- Inner surface teeth bite into conduit or tubing to enhance clamping and sealing action
- Fitting ferrule designed to accept variations in conduit sizes and field conduit cuts
- Smooth ferrule profile reduces friction to ensure a tight conduit-to-fitting seal
- Friction-reducing ridges and teeth provide a true double seal and high pullout resistance
- Elongated gland nut offers additional strain relief for 90° pull and easy hand grip
- Rugged low-profile nonmetallic body and gland construction provides space savings
- Captivated sealing O-Ring features predetermined compression to provide a reliable seal at enclosure
- Steel locknut firmly secures fitting to box or enclosure

FIGURE 1
(STRAIGHT)FIGURE 2
(145 DEGREE)FIGURE 3
(90 DEGREE)

Plastic Bullet® Liquidtight Fittings for T&B LTC Non-Metallic Liquidtight Conduit Type B and T&B EFC Flexible Tubing

This engineering breakthrough meets the demand for a tough, reusable, non-metallic liquidtight fitting for use with XTRA FLEX® Type B conduit or flexible tubing. The BULLET® non-metallic fitting provides a reliable liquidtight seal that combines high pullout resistance and ease of installation.

Engineered to meet your needs.

The BULLET® non-metallic fitting meets your performance requirements when terminating Type B liquidtight non-metallic conduit or flexible non-metallic tubing to a box or enclosure with knockout opening or threaded hub. Fittings meet the watertight requirements for NEMA Type 4 and Type 6 enclosures and conform to UL514B and CSA No. 22.2 #227.2 specifications.

Ease of installation.

Installations can be performed quickly and easily because BULLET® liquidtight fittings can be installed without disassembly. BULLET® nonmetallic fittings are resistant to numerous caustics and solvents.

The BULLET® fitting is economical because it can be used over and over again without sacrificing the quality of the original seal. When used with the XTRA FLEX® raceway system, you can meet most machine or industrial requirements where liquidtight protection is needed.

Corrosion resistant. Built to take it.

The BULLET® liquidtight fitting is manufactured from weather-resistant thermoplastic materials and is suitable for indoor or outdoor corrosive environments. The BULLET® fitting is resistant to detergents, cleaners, oils, sanitizers, paints, cutting fluids and wire pulling compounds — just about any liquid usually found in industrial, plant or marine environments. It also surpasses industry standards for cold impact and simulated hammer blows.



CAT. NO.	FIG.	TRADE SIZE (IN.)	A ±.015 (.040) (IN.) (MM)	*B ±.035 (0.90) (IN.) (MM)	C ±.015 (0.40) ACROSS CORNERS (IN.) (MM)	MIN. THROAT DIA. D (IN.) (MM)	E THREAD NPT (IN.)	F* (IN.) (MM) APPROX.
LT38P	1		.570	1.556 (40.51)	1.354	.417		—
LT438P	2	1/2	(14.48)	2.012 (51.10)	(34.38)	(10.59)	1/2-14	1.534 (38.95)
LT938P	3			1.380 (35.05)				1.880 (47.75)
LT50P	1		.570	1.636 (41.55)	1.448	.550		—
LT450P	2	1/2	(14.48)	2.092 (53.14)	(36.78)	(13.97)	1/2-14	1.590 (40.38)
LT950P	3			1.488 (37.82)				1.986 (50.44)
LT75P	1		.582	1.757 (44.63)	1.740	.740		—
LT475P	2	1/2	(14.78)	2.452 (62.28)	(44.20)	(18.90)	1/2-14	1.821 (46.25)
LT975P	3			1.790 (45.47)				2.212 (56.13)
LT100P	1		.726	1.923 (48.84)	2.068	.940		—
LT4100P	2	1	(18.44)	2.684 (68.17)	(52.53)	(23.88)	1-11/16	2.034 (51.66)
LT9100P	3			2.104 (53.44)				2.508 (63.70)
LT125P	1		.750	2.164 (54.97)	2.494	1.257		—
LT4125P	2	1 1/2	(19.05)	3.264 (82.91)	(63.35)	(31.93)	1 1/2-11 1/2	2.385 (60.58)
LT9125P	3			2.564 (65.13)				2.856 (72.54)
LT150P	1		.767	2.353 (59.77)	2.784	1.453		—
LT4150P	2	1 1/2	(19.48)	3.606 (91.57)	(70.71)	(36.91)	1 1/2-11 1/2	2.604 (66.14)
LT9150P	3			2.854 (72.49)				3.144 (79.86)
LT200P	1		.794	2.606 (66.17)	3.362	1.883		—
LT4200P	2	2	(20.17)	4.210 (106.93)	(85.38)	(47.83)	2-8	3.060 (77.47)
LT9200P	3			3.432 (87.17)				3.675 (93.34)

* After Assembly
UL File No. E-23016
CSA File No. 52391